

Data Sheet

Installation Diagram



Add-on Units

EN | Edition 04/2024



Dimensions (mm)

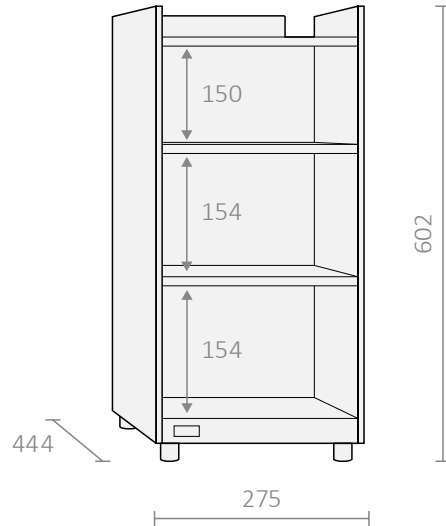
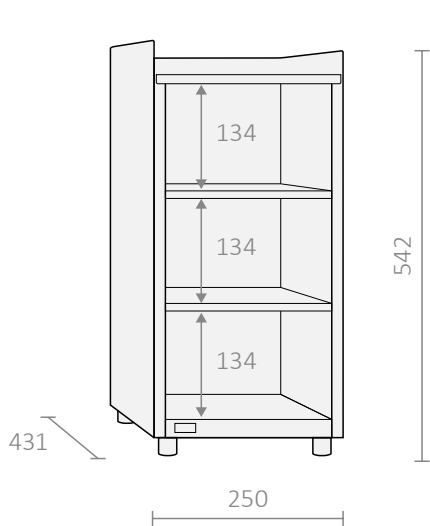

	S1	S2	S300	S500
W	x	x		
Description	Cup warmer			
Capacity (Cups)	≤ 104*			
Weight	17 kg			
Rating	220-240 V ~ 50/60 Hz			
Power	0.16 kW			

	S1	S2	S300	S500
W	x	x		
Description	Cup warmer			
Capacity (Cups)	≤ 120**			
Weight	16.2 kg			
Rating	220-240 V ~ 50/60 Hz			
Power	0.16 kW			

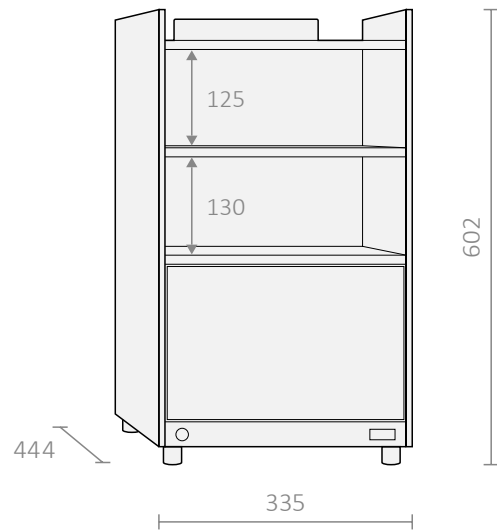
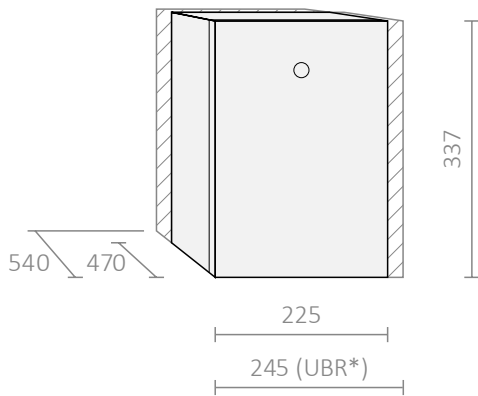

	S1	S2	S300	S500
L4 Series	x	x	x	x
Description	Refrigerator			
Capacity (Milk)	4 l			
Capacity (Cups)	-			
Weight	15 kg			
Rating	220-240 V ~ 50/60 Hz			
Power	0.08 kW			
Current	0.35 A			
Refrigerant	R600a 12 g			

	S1	S2	S300	S500
Fh4 Series	x	x		
Description	Refrigerator with cup warmer			
Capacity (Milk)	4 l			
Capacity (Cups)	≤ 120**			
Weight	26.6 kg			
Rating	220-240 V ~ 50/60 Hz			
Power	0.22 kW			
Current	1.0 A			
Refrigerant	R600a 11 g			

*In the counter under the coffee machine, sufficient ventilation for the cooling unit must be ensured.
 **ø 80 mm | ± 75 mm

Dimensions (mm)

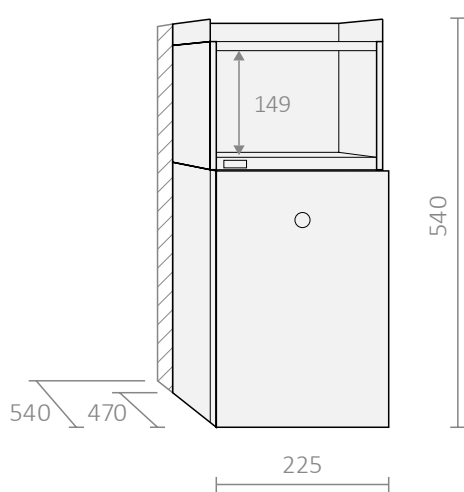

S1
S2
S300
S500

L4v Series		S1	S2	S300	S500
Description	Refrigerator with cup warmer	x	x		
Capacity (Milk)				4 l	
Capacity (Cups)				≤ 52**	
Weight				20 kg	
Rating				220-240 V ~ 50/60 Hz	
Power				0.14 kW	
Current				0.7 A	
Refrigerant				R600a 12 g	

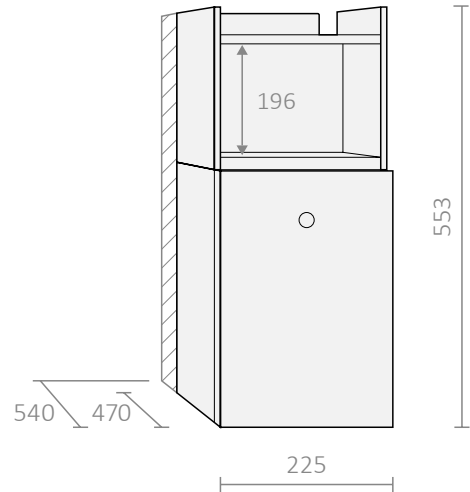

S1
S2
S300
S500

L4v Series		S1	S2	S300	S500
Description	Refrigerator with dispenser	x	x		
Capacity (Milk)				4 l	
Capacity (Cups)				≤ 52**	
Weight				21 kg	
Rating				220-240 V ~ 50/60 Hz	
Power				0.14 kW	
Current				0.7 A	
Refrigerant				R600a 12 g	

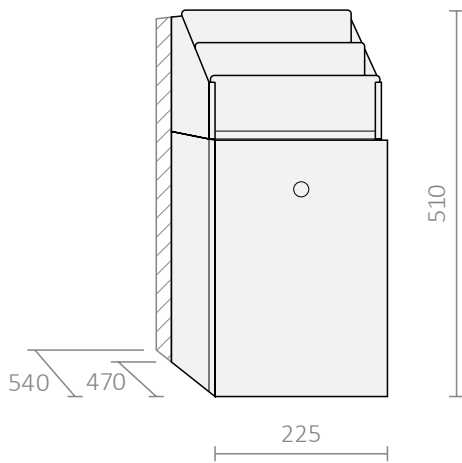

S1
S2
S300
S500

L4s Series		S1	S2	S300	S500
Description	Refrigerator with dispenser	x	x		
Capacity (Milk)				4 l	
Weight				18.5 kg	
Rating				220-240 V ~ 50/60 Hz	
Power				0.08 kW	
Current				0.35 A	
Refrigerant				R600a 12 g	

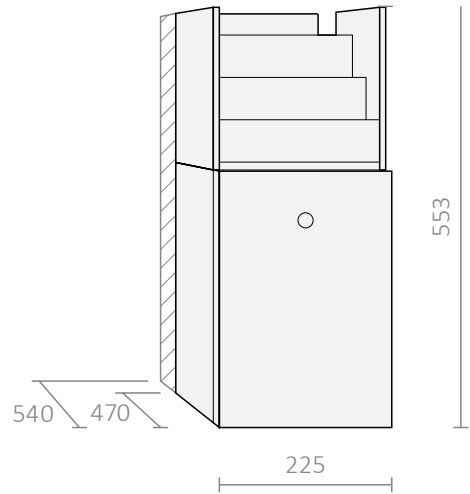

S1
S2
S300
S500

L4s Series		S1	S2	S300	S500
Description	Refrigerator with dispenser	x	x		
Capacity (Milk)				4 l	
Weight				19.5 kg	
Rating				220-240 V ~ 50/60 Hz	
Power				0.08 kW	
Current				0.35 A	
Refrigerant				R600a 12 g	

**ø 80 mm | ± 75 mm

Dimensions (mm)

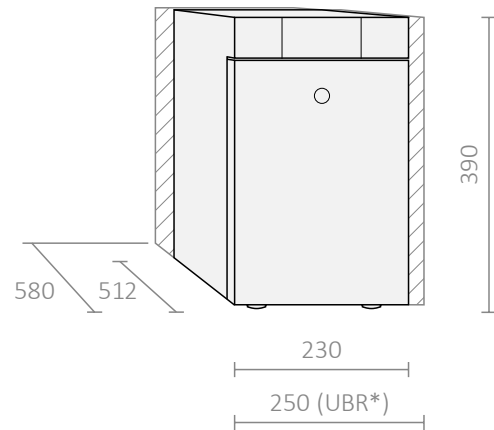
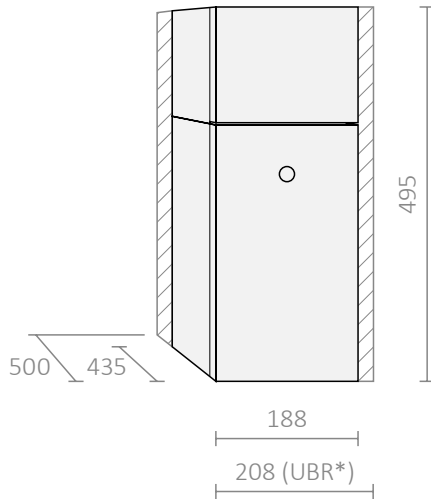

	S1	S2	S300	S500
L7 Series	x	x	x	x
Description	Refrigerator			
Capacity (Milk)	7 l			
Weight	18.5 kg			
Rating	220-240 V ~ 50/60 Hz			
Power	0.06 kW			
Current	0.23 A			
Refrigerant	R600a 14 g			

	S1	S2	S300	S500
L9 Series	x	x	x	x
Description	Refrigerator			
Capacity (Milk)	9 l			
Weight	19.5 kg			
Rating	220-240 V ~ 50/60 Hz			
Power	0.07 kW			
Current	0.3 A			
Refrigerant	R600a 12 g			

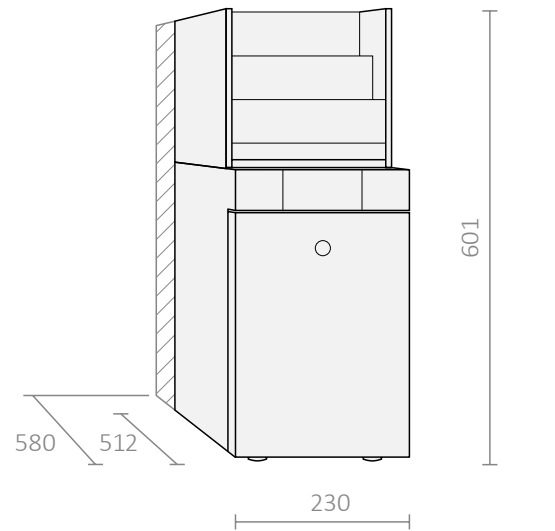
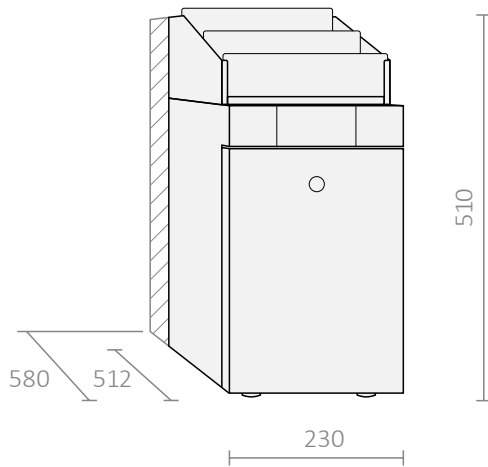

	S1	S2	S300	S500
L9s Series	x	x		
Description	Refrigerator with dispenser			
Capacity (Milk)	9 l			
Weight	21.5 kg			
Rating	220-240 V ~ 50/60 Hz			
Power	0.07 kW			
Current	0.3 A			
Refrigerant	R600a 12 g			

	S1	S2	S300	S500
L9s Series			x	x
Description	Refrigerator with dispenser			
Capacity (Milk)	9 l			
Weight	22.5 kg			
Rating	220-240 V ~ 50/60 Hz			
Power	0.04 kW			
Current	0.7 A			
Refrigerant	R600a 12 g			

*In the counter under the coffee machine, sufficient ventilation for the cooling unit must be ensured.

Dimensions (mm)

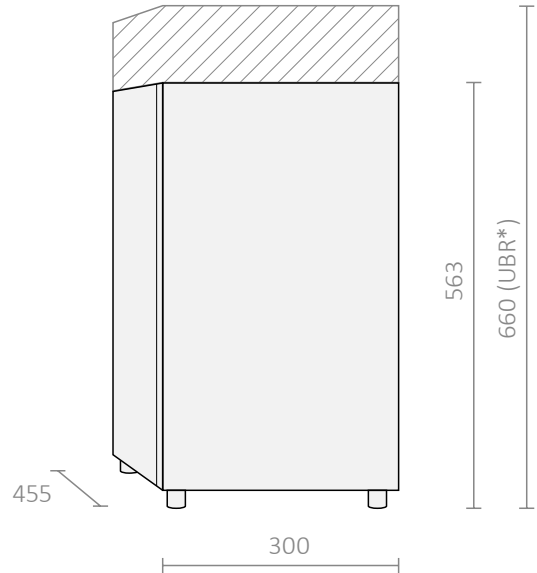
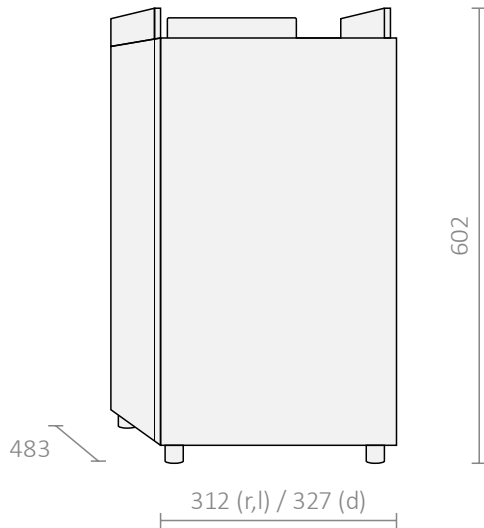

	S1	S2	S300	S500
R10 Series	x	x		
Description	Refrigerator			
Capacity (Milk)	10 l			
Weight	30.5 kg			
Rating	220-240 V ~ 50/60 Hz			
Power	0.12 kW			
Current	0.7 A			
Refrigerant	R600a 12 g			

	S1	S2	S300	S500
R10-UBR Series	x	x	x	x
Description	Refrigerator			
Capacity (Milk)	10 l			
Weight	30.5 kg			
Rating	220-240 V ~ 50/60 Hz			
Power	0.12 kW			
Current	0.7 A			
Refrigerant	R600a 12 g			

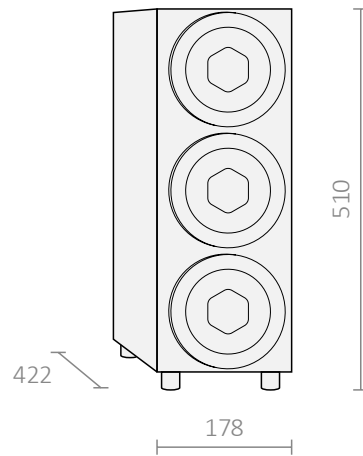
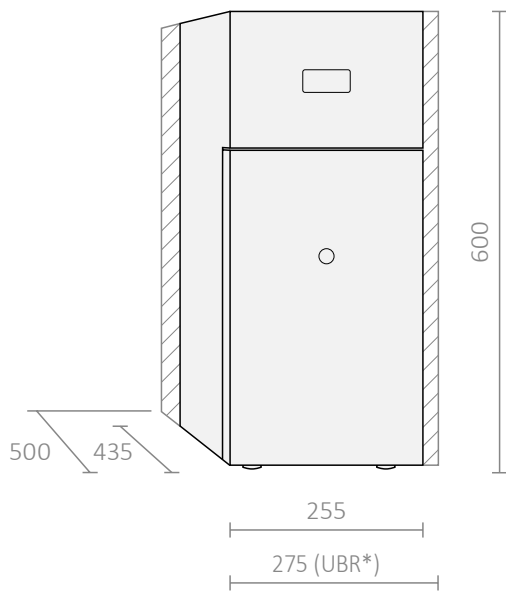

	S1	S2	S300	S500
L15 Series	x	x	x	x
Description	Refrigerator			
Capacity (Milk)	15 l			
Weight	23 kg			
Rating	220-240 V ~ 50/60 Hz			
Power	0.08 kW			
Current	0.35 A			
Refrigerant	R600a 18 g			

	S1	S2	S300	S500
CD	x	x	x	x
Description	Cup dispenser			
Capacity (cups)	≤ 270**			
Weight	14.2 kg			

*In the counter under the coffee machine, sufficient ventilation for the cooling unit must be ensured.
 **ø 70 mm | ± 90 mm

Dimensions (mm)

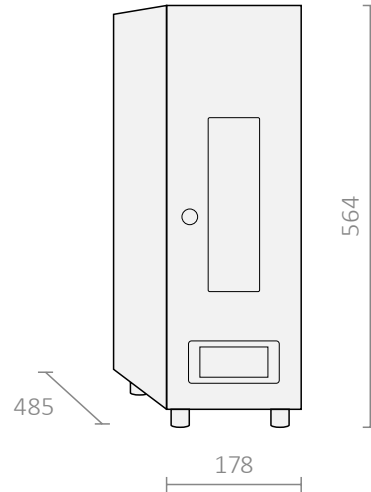
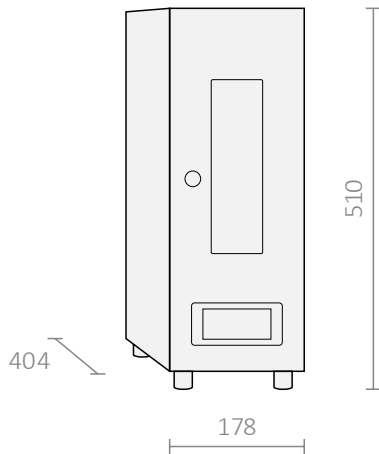

		S1	S2	S300	S500
A**		x	x		
Description	Aroma module				
Capacity (Bottles)	3x 1 l				
Bottles	ø max. 85 mm ± max. 320 mm				
Weight	16 kg				

		S1	S2	S300	S500
A**		x	x		
Description	Aroma module				
Capacity (Bottles)	3x 1 l				
Bottles	ø max. 85 mm ± max. 320 mm				
Weight	18 kg				

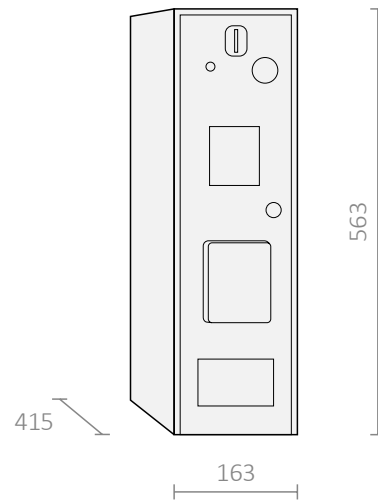
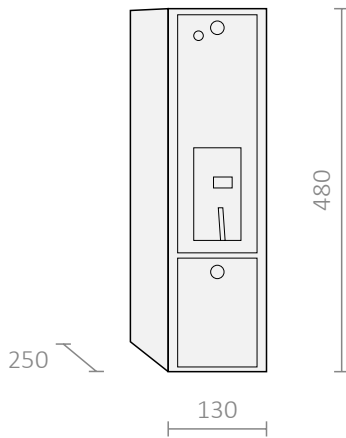

		S1	S2	S300	S500
Flex CA		x	x	x	x
Description	Coin Acceptor				
Weight	5.5 kg				

		S1	S2	S300	S500
CC*		x	x	x	x
Description	Coin Changer				
Weight	23.2 kg				

*only attached left
**only attached right

Dimensions (mm)

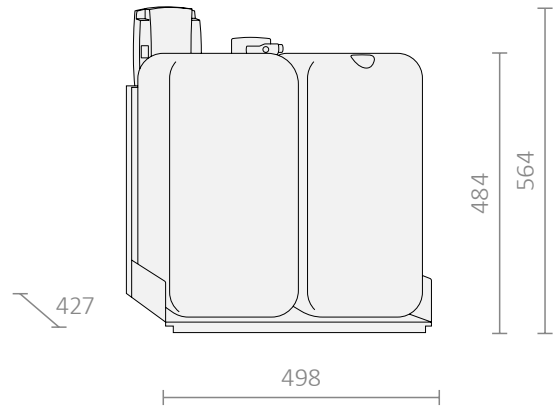
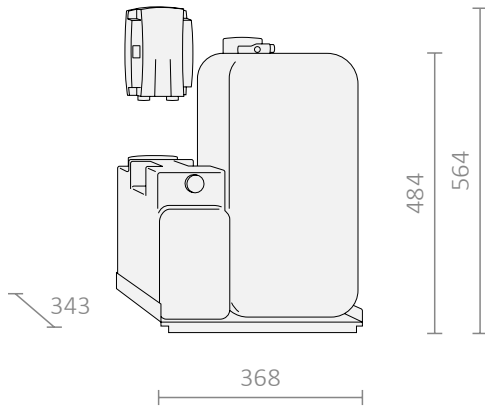

		S1	S2	S300	S500
wss***		x	x	x	x
Description	Water self supply				
Capacity (fresh/waste water)	< 25/12 l				
Weight	4.5 kg				

		S1	S2	S300	S500
wss-H		x	x	x	x
Description	Water self supply				
Capacity (fresh/waste water)	< 25/25 l				
Weight	5.2 kg				

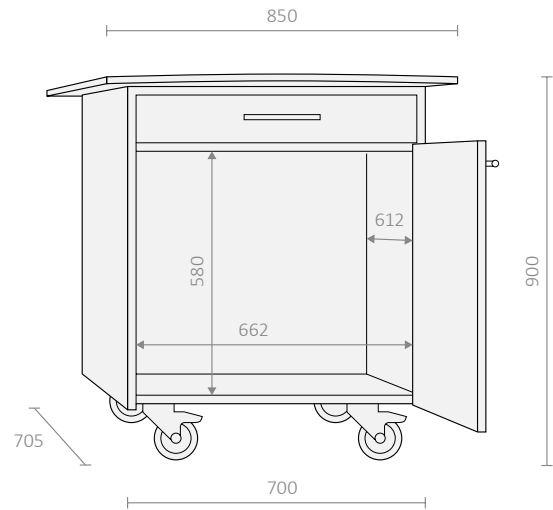
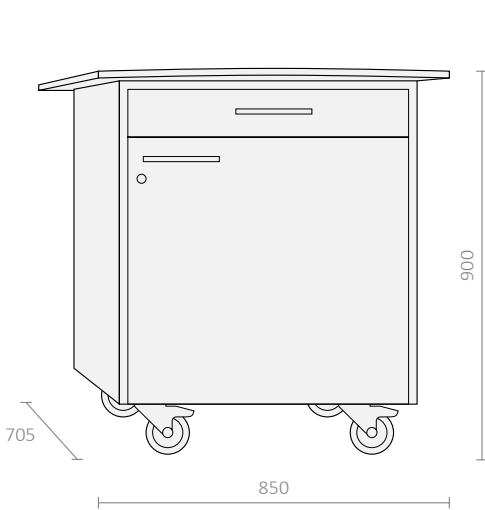

		S1	S2	S300	S500
T		x	x	x	x
Description	Mobile cart				
Weight	55 kg				
Load	max. 150 kg				

***not available for CF-Models

Dimensions (mm)

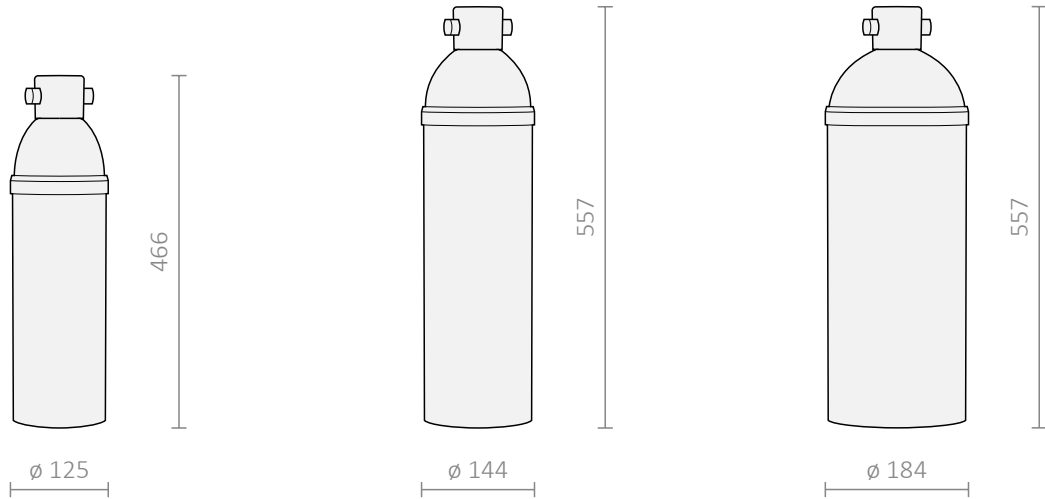

		\$1	\$2	\$300	\$500
C300		x	x	x	x
Description	Water filter				
Weight (dry/wet)	2.8 kg 4.2 kg				

		\$1	\$2	\$300	\$500
C500		x	x	x	x
Description	Water filter				
Weight (dry/wet)	4.6 kg 6.9 kg				

		\$1	\$2	\$300	\$500
C1100		x	x	x	x
Description	Water filter				
Weight (dry/wet)	7.7 kg 12.5 kg				

Reservation of intellectual property

This document and its entire contents are protected by copyright and are the intellectual property of Rex-Royal AG. The document must not be passed on to third parties and is only allowed to be used for the intended purpose. It must be kept in a safe place and protected from access by unauthorised persons.



Rex-Royal AG | Swiss Coffee Machines | Industriestrasse 34 | CH-8108 Daellikon / Zuerich
T: +41 44 847 57 57 | info@rex-royal.ch | www.rex-royal.ch

Subject to change