



# Rex-Royal S500 MCT-HS

Home and hospital catering



# High capacities

## For home and hospital catering

### The Rex-Royal S500 MCT-HS

has been specially designed by us for home and hospital catering in order to dispense large quantities of coffee and fresh milk portions into jugs in a short time. The coffee is freshly ground, so the products can be dispensed with a high quality level, fully automatically.

The S500 MCT-HS is a powerhouse and delivers up to 150 servings of coffee and milk of 2 dl each per hour, even in the stand-alone version. Depending on the requirements, the S500 MCT-HS is also available as a twin version. If desired, the system can also be installed stationary without a mobile trolley. Each machine unit has two sensor-monitored double beverage outlets for parallel dispensing of coffee and fresh milk. The outlet sensors enable a direct product restart on contact and deliver the beverages without any time loss. At the same time, up to 58 litres of hot water per hour can be drawn from the central hot water outlet.

The S500 MCT-HS is equipped as standard with two individually adjustable precision grinders which grind the coffee simultaneously. This means that the beans are ground in half the time. The milk system has been optimised for performance and was specially developed to meet the high capacity requirements. Equipped with the proven quality milk pump, flexible adjustment of the milk temperature is guaranteed.



Rex-Royal has designed mobile trolley solutions in CNS especially for conveyor belt filling, which meet the special requirements of hospital and home catering. These mobile solutions are robust, durable and, thanks to them being produced in the company's own metal-working shop, can be supplemented to meet specific customer requirements. The open construction is specifically designed for care gastronomy and allows flexible installations, practical handling and easy cleaning. The mobile trolleys are equipped as standard with collection containers (Gastronorm containers) for the coffee grounds and a water filter system.

Rex-Royal AG develops and produces in Daellikon near Zurich. This ensures a high quality standard for our products and allows us to respond flexibly and directly to customers' wishes.



\* Height freely definable from 80 to 255 mm

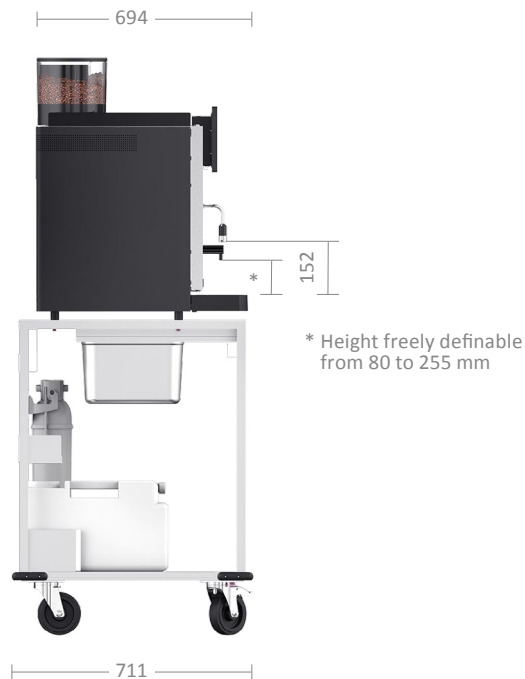

### Capacity (per unit)

Bean container	
with 2 grinders	1.5 / 1.5 kg
Grounds container	4 kg

### Water connection

Pipe	G 3/8" L = 2000 mm
Water pressure	1 - 5 bar
Total hardness	5-8 dH° / 8-14 fH°
Chlorine content	< 30 ppm/l

### Voltage (per unit)

380-415V | AC 50/60 Hz | 8.0-9.5kW



Rex-Royal AG | Industriestrasse 34 | CH-8108 Daellikon / Zuerich  
T: +41 44 847 57 57 | info@rex-royal.ch | www.rex-royal.ch